

MATRIX I ONE LINE INK JET PRINTER

OPERATING INSTRUCTIONS
AND
PARTS MANUAL



KIWI CODERS CORPORATION
265 E. MESSNER DR.
WHEELING, IL 60090-6495 U.S.A.
847/541-4511 FAX: 847/541-6332

www.kiwicoders.com

Email: kiwicoders@aol.com

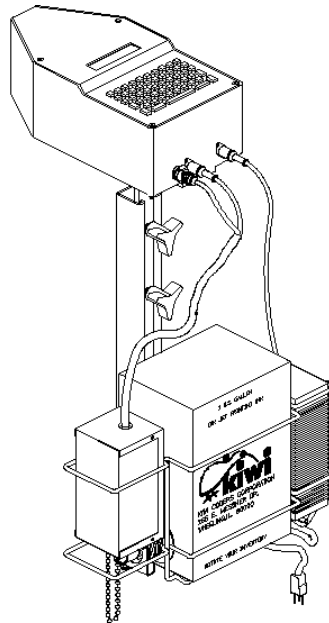

SERIAL NUMBER: _____

Version # _____

Part No. F063366
Revision A 1203

Equipment Checklist

Listed below are the items included with your MATRIX I System.

ITEM	DESCRIPTION	PART NO.	QTY
1	Assembly, Print head case	FC63354	1
2	Back flush syringe	F060549	1
3	Assembly, Mounting clamp	F060055	1
4	Vertical mount	F063032	1
5	Assembly, Wire form basket	F063030	1
6	Assembly, Pump	FC63233	1
7	Power supply, (With 76" detachable power cord.)	F063327	1
8	---	---	---
9	Nozzle plate, 1 Line (Refer to P.O. for part no. then refer to chart "A" below)	-	1
10	Ink, Data dot 1 gal black (not included w/ system) (Refer to chart "B" for optional inks)	D060015	1
11	Rivet, blind 1/8 Dia. (shown for reference only)	F063074	2
12	Nameplate with serial and model numbers (shown for ref only)	-	1
13	Nozzle plate cleaner (optional, not pictured)	D060009	1
14	Instruction Manual (not pictured)	F063366	1

CHART A		
Character height	System part number	Nozzle plate part number
3/8"	R063355	FC63359
1/2"	R063356	FC63361
3/4"	R063357	FC63363
1"	R063358	FC63348

CHART B	
Ink color	Part no.
BLACK	D060015
RED	D060016
BLUE	D060017
GREEN	D060018

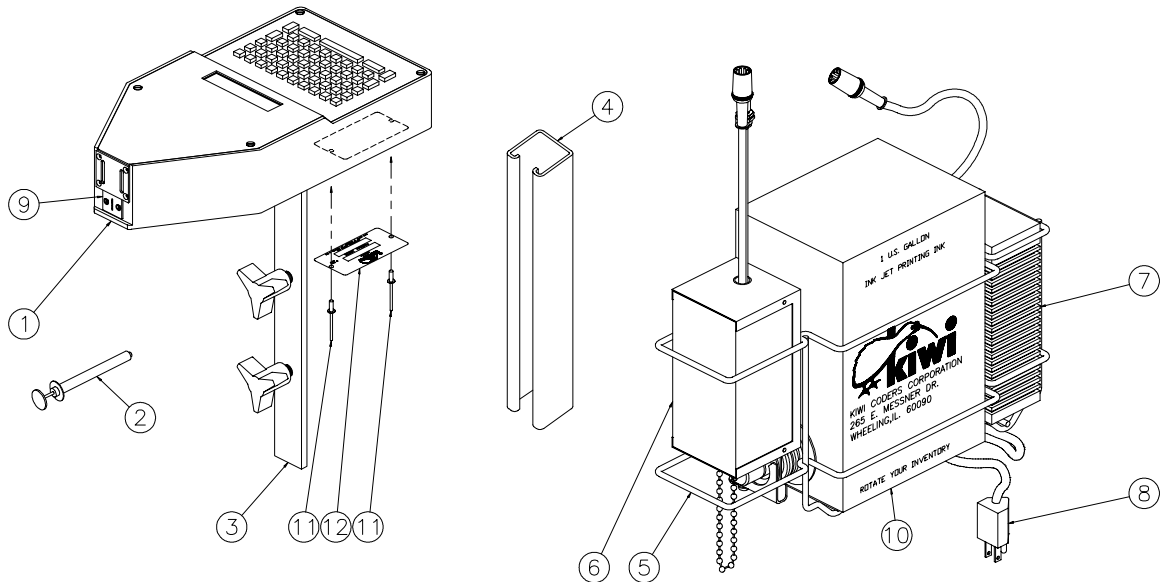

CONDITIONS OF LIMITED WARRANTY
TERMS AND CONDITIONS OF SALE

PAYMENT TERMS: Subject to establishment of satisfactory credit, terms are net 30 days from date of invoice with no cash discount allowed. To avoid delay in order processing, new customers should include name of their bank along with three credit references or provide cash in advance.

SHIPPING TERMS: Prices on all items are F.O.B. Wheeling, Illinois, with no transportation allowed.

MINIMUM BILLING CHARGE: Orders amounting to \$50.00 net or less will be billed at \$50.00 plus transportation cost.

RETURNS FOR CREDIT: No returns for credit will be accepted unless written permission has been obtained from an authorized employee of Kiwi Coders Corporation. Only standard equipment in active demand and in new condition will be considered for credit allowance. Credit will be applied to customer's account and will be based on prices prevailing at time of return or invoice price, whichever is the lower, subject to deduction for handling and an additional deduction for expenses incurred in restoring goods to sellable condition. Specially manufactured equipment cannot be returned for credit.

RETURNS FOR REPAIR: No equipment should be returned for repair without permission from an authorized representative of Kiwi Coders Corporation. Equipment returned for repair due to causes not covered by Warranty should be returned prepaid to Kiwi Coders. Kiwi Coders will notify the customer of the estimated cost of repair or that the equipment is repairable prior to proceeding with the repair, if requested.

CANCELLATION OR CHANGES IN SPECIFICATIONS: Orders that have been entered for production are not subject to cancellation or change in specifications without our written consent. A cancellation charge may be applicable.

PRICES: Each shipment or partial shipment of an order will be priced separately in accordance with Kiwi's prices in effect at the time of shipment.

CLAIMS FOR DAMAGE OR LOSS IN TRANSPORTATION: All claims for damage or loss in transportation should be made to Kiwi Coders Corporation. Written notice of each such claim must be made to Kiwi Coders within five days of making claim.

CLAIMS FOR ERRORS, SHORTAGES OR REJECTIONS: All claims for errors, shortages or rejection of product received from Kiwi Coders must be made within 15 days after receipt of shipment.

EXCUSABLE DELAYS OR FAILURES: Kiwi Coders shall not be liable for delays in delivery or failure to manufacture due to causes beyond reasonable control or due to acts of God, acts of purchaser, acts of civil or military authority, priorities, fire, strikes, floods, epidemics, quarantine restrictions, war, riot, delays in transportation and delays in U.S. Mail, car shortages and inability due to causes beyond its reasonable control to obtain necessary labor, material or manufacturing facilities. In the event of reduced production due to any of the preceding causes, Kiwi Coders reserves the right to allocate such reduced production based upon delivery schedules in force at the time of delay.

U.S. PATENT PROTECTION: Kiwi Coders shall hold the purchaser harmless against any claim for infringement by Kiwi Coders products of the United States letters patent only and no others; provided that the purchaser notifies Kiwi Coders of any such claim within five days of receipt of the first notification of infringement and Kiwi Coders is given full opportunity to defend any action for patent infringement.

WARRANTY: Kiwi Coders MATRIX I Ink Jet system is warranted against defective material and workmanship for a period of 180 days from date of invoice. This warranty is limited to repair or replacement at our factory and we will not assume responsibility or accept charges for unauthorized repairs even through equipment proved to be defective. Kiwi Coders is not responsible for damage to equipment by reason of improper installation or attempting to operate this equipment under conditions for which the equipment is not designed. Failure to do so can result in personal injury.

INK: Only Kiwi Coders approved inks may be used in the MATRIX I System. Use of other inks will render the warranty null and void.

MATRIX I WARRANTY REGISTRATION CARD

This sheet must be completed fully and returned to Kiwi Coders Corporation for warranty to be in effect.

COMPANY NAME: _____

COMPANY ADDRESS: _____

PURCHASERS NAME: _____

PURCHASE DATE: _____

PHONE NUMBER: _____

MATRIX I SERIAL NUMBER: _____

WHERE DID YOU PURCHASE YOUR MATRIX I: _____

TYPE OF ITEM BEING PRINTED: _____

LINE SPEED IN FEET PER MINUTE / METERS PER MINUTE: _____

NUMBER OF CHARACTERS TO BE PRINTED: _____

INSTALLATION DATE: _____

PLEASE PHOTOCOPY AND RETURN THIS PAGE FOR YOUR MATRIX I WARRANTY TO BE IN EFFECT.

SO THAT WE MAY BE OF BETTER SERVICE TO YOU, PLEASE MAKE COMMENTS OR SUGGESTIONS ON YOUR MATRIX I SYSTEM: THANK YOU.

COMMENTS:

SAFETY and ELECTRICAL PRECAUTIONS

Read, understand and follow these safety precautions before attempting to operate this equipment. Failure to do so can result in personal injury.

1. Only trained personnel should operate this equipment.
2. Wear safety goggles when working with the ink system.
3. Wear protective gloves when working with the ink systems.

The LCD module is made of glass, with a Polarizer that is a soft material and can be easily scratched. The Liquid Crystal may leak out if the LCD becomes broken. In case of contact with skin or clothing, please wash with soap immediately.

To reduce electrical noise, the MATRIX I System should be connected directly to its own branch circuit. Use only a properly grounded outlet. Do not use extension cords. A 15-Amp fuse or circuit breaker must externally protect the input power.

1. Check for 104 to 127 volts between AC hot & AC neutral.
2. Check for 104 to 127 volts between AC hot & AC ground.
3. Check for less than three volts between AC neutral & ground.
4. Do not install MATRIX I until voltages are within the above ranges.

Variations in incoming power may adversely affect system operation. The system is capable of operating for brief periods of time through voltage dips and surges. However, if available power is subject to severe or frequent voltage fluctuations, a voltage regulator should be installed.

A proper electrical ground is essential for proper operation of the system, and helps limit the effects of noise due to electromagnetic interference (EMI).

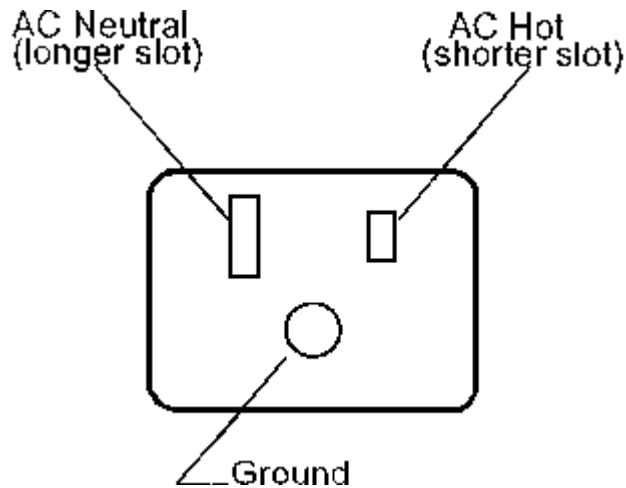

Figure 1

MATRIX I INSTALLATION AND MOUNTING

1. Locate mounting hardware (mounting clamp assembly – P/N F060055, vertical mount – P/N F063032).
2. Locate mounting point on conveyor line. Mounting location should have box guide rails to keep box at a proper 1/8" (3.2mm) distance from the front of the MATRIX I controller.
3. Attach the vertical mount (P/N F063032) to the conveyor line by drilling two holes approximately 4" (101.6mm) apart. Bolt vertical mount to conveyor line. (Mounting hardware not included.)
4. Insert mounting clamp assembly (P/N F060055), into top of vertical mount (P/N F063032). Insert one-gallon ink basket into bottom of vertical mount and tighten bolts.
5. Mount MATRIX I controller onto top of mounting clamp (P/N F060055).
6. Connect MATRIX II ink pump module (P/N FC63233) to the one gallon Bag-in-box ink container. (See APPENDIX A). Place ink pump module and one gallon Bag-in-box ink container in the one-gallon ink basket (P/N F063030). Note: The Matrix I and the Matrix II both use the same ink pump.
7. Place power supply module (P/N F063327) in holder located on one-gallon ink basket (P/N F063030).
8. Connect power cord to power supply module (P/N F063327).
9. Plug the power cord into an appropriate power source. **NOTICE:** There is no power switch on the MATRIX I. To turn power on and off, the power supply connector must be unplugged from the rear of the MATRIX I.
10. Connect power lines to the MATRIX I controller but do not connect the ink line until the pump has been primed to remove any air.
11. To prime the ink pump upon new installation, or after changing the ink box, follow the procedure below:
 - a. Connect ink pump module to bag-in-box container.
 - b. Connect ink pump module power line to MATRIX I Controller.
 - c. **DO NOT** connect the ink line to the MATRIX I controller.
 - d. Place MATRIX I System into printing mode (Green light on).
 - e. Press the tip of the ink line into a paper towel making sure the ink flow is not blocked by the paper towel.
 - f. Ink will begin flowing when pump is primed.

Your MATRIX I System is shipped to you with solvent in the ink system but it is typical for air to enter the ink system during shipping. Air in the ink system will produce poor print quality. The MATRIX I system will require flushing by pressing the flush key to remove the solvent and any air from the ink system. The flush key must be held down for at least 3 seconds after ink appears, longer if air is still being noticed. (An ink stream that appears as if it is 'bubbling' out of the nozzle is an indication that there is still air trapped in the system.) Flushing the system may also be required after changing ink containers.

IMPORTANT: DO NOT mount the MATRIX I Controller with the ink nozzles pointed up. Ink may drip back into the controller and cause electrical damage.

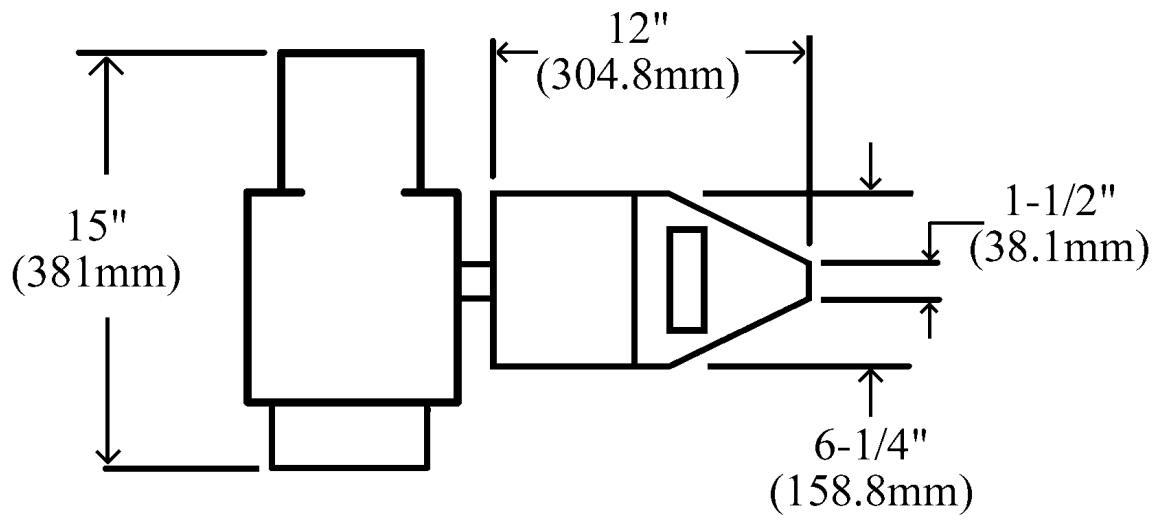

Figure 2 Rough dimensions

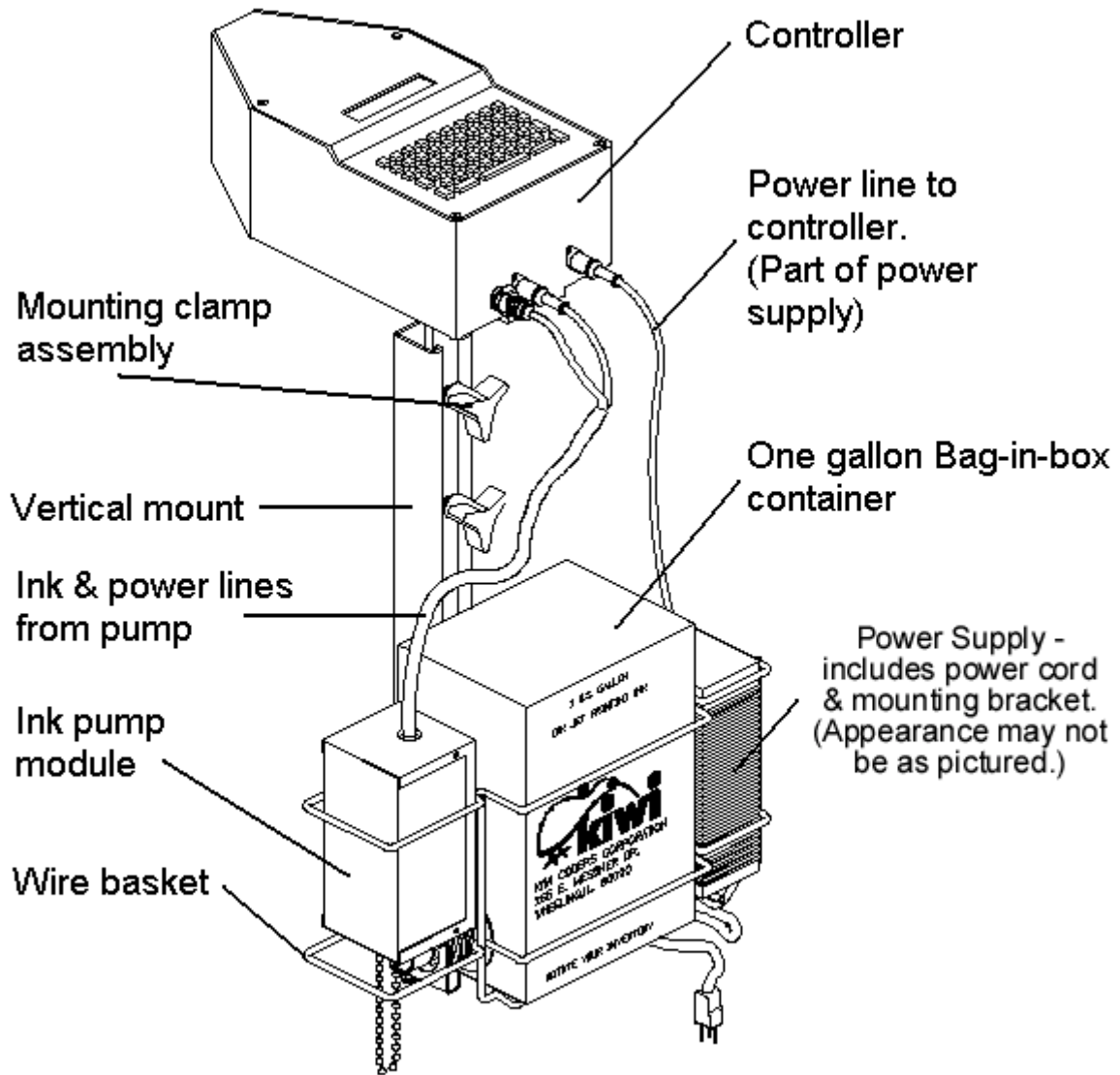

Figure 3

MATRIX I FUNCTION KEYS-EXPLANATION

All function keys are located on the top row of the keyboard, with black letters. While in the printing mode, these function keys may be pressed to modify values that were input at message setup time.

[M] = **Message margin** (The distance a message will begin printing from the leading edge of the box.) Minimum distance is .80" (20.3mm). Maximum distance is 40" (1.016m)

- a. Press [M] Margin Key.
- b. Use [↑] and [↓] arrows to change message margin by 0.1" (2.5mm).
- c. Use the [SHIFT] + [↑] or [SHIFT] + [↓] to change margin by 1.0" (25.4mm)
- d. Press [ENTER] Key.

[W] = **Message width** (Used for increasing or decreasing message length.) Minimum: 50% Maximum: 200%

- a. Press [W] Width Key.
- b. Use [↑] and [↓] arrows to change message width in 10% increments.
- c. Press [ENTER] Key.

[D] = **Date** (Used for changing system date).
(The SHIFT-D key combination can be used to insert or remove the slashes in the date.)

- a. Press [D] Date Key.
- b. Type in correct date. Example: 31302 (i.e. March 13th, 2002)
- c. Press [ENTER] Key.

[T] = **Time** (Military Time).

- a. Press [T] Time Key.
- b. Type in the correct time: Example: 1500 (i.e. 3pm)
- c. Press [ENTER] Key.

[C]= **Count**

- a. Press [C] Count Key.
- b. Type in the correct count for the NEXT box. Example: 1234 or 0001
- c. Press [ENTER] Key.

[S]= **Dot size** (Used for increasing or decreasing the amount of ink being dispensed to create larger or smaller dots). The MATRIX I now has the ability to select a greater range of dot sizes.

- a. Press [S] Dot Size Key.
- b. Use [↑] and [↓] arrows to change dot size. Dot size range: 1 to 9
- c. Press [ENTER] Key.
- d. Use the [↑] arrow to select high pressure (7psi) or the [↓] arrow to select low pressure (3psi).
- e. Press [ENTER] Key.

MATRIX I FUNCTION KEYS-EXPLANATION continued

[F]= **Flush** (Used for flushing ink through system, to clear obstructions causing bad prints).
NOTE: To flush the MATRIX I System, the green "ON" light must be turned off by pressing the "OFF" key.

1. Press and hold the [F] Flush Key. The Pump will generate 7psi during flushing to better clear obstructions. (If you are printing at the low pressure setting (3psi), the next several prints will be darker until the pressure drops back down.)
2. Release Flush Key to stop flushing. NOTE: All 16 valves should give a steady stream of ink until the flush key is released. A plastic bottle or absorbent paper towels should be used to capture the ink.

[] = **'Multi-Function'** Key. (Unmarked)

1. When in message entry mode: Used in combination with the shift key, it allows the operator to enter the 'special field' into the message
2. When in run mode: Allows the operator to change the Special field.

[e] = **Escape** Key. Allows the operator to move backwards in the program.

[d] = **Delete** Key. Allows the operator to delete numbers or letters when entering a message.

[ON] Pressing this key will immediately take you to the "Start print?" screen. While in "RUN" mode, a green LED will light under this key.

Note: This key is disabled if you are already in print mode.

[OFF] Pressing this key will immediately take you out of print mode, turn off the indicator LED, shut off the ink pump and display the "Press any key" screen.

[Shift-S] **Save message** is used to re-save a message after changing any of the items that get stored with the message. (Width, dot size, pressure or margin.)

- a. Press [Shift and the letter S]
- b. Answer yes to the "save message" prompt.
- c. The message number defaults to the number used to originally save the message (if any). Just press enter to accept the same number or use the delete key to remove the old number and type in a new message number.

MATRIX I SETUP

```
( R ) R u n / ( S ) S e t u p
S e l e c t ( R / S ) ?
```

Setup mode will cycle through the following screens, allowing you to set default values for various operating parameters. Language and "date format" are the only 2 that can **only** be changed here. Everything else can be adjusted through the function keys.

1. Language

```
L a n g u a g e S e l e c t
1 ) E n g l i s h 2 - 7 ) O t h e r
```

The languages available are:

1) English, 2) Spanish, 3) French, 4) German,
5) Italian, 6) Finnish and 7) Portuguese.

- Pressing a number between 1 and 7 selects the unit operation language. (The language the screen prompts are in.)
- Pressing [ENTER] causes movement to the next screen.

NOTE: The language selection will be remembered even after removing power.

2. Time

```
C u r r e n t T i m e 1 5 : 0 0
N e w T i m e 0 : 0 0
```

- Type in the four digit military time, (example 1500), and press [ENTER].
- Pressing [d] deletes the last digit entered.
- Pressing [ENTER] causes movement to next screen.
- Pressing [e] causes a return to the run/set up screen.

3. Date

```
T o d a y s D a t e 1 2 / 3 1 / 0 1
N e w D a t e 0 0 0 0 0
```

- Type in the six digit date with the month first, (example 031302), and press [ENTER].
- Pressing [d] deletes the last digit entered.
- Pressing [ENTER] causes movement to next screen.
- Pressing [e] causes a return to the run set up screen.

NOTE: Pressing the Shift and the white letter "D", switches between slashes and spaces in the date.

4. Date Format

```
1 ) m m / d d / y y 2 ) A l f / N u m
3 ) d d d 4 ) d d / m m / y y 1 - 4
```

- Pressing a number from 1 to 4 will select the date format you can use in your messages and then automatically move on to the next screen. Any other number will be ignored.
 - Pressing [1], sets the date format to Numeric, with the month first.
 - Pressing [2], sets the date format to Alpha/numeric.
 - Pressing [3], sets the date format to Julian.
 - Pressing [4], sets the date format to Numeric, with the day first.
- Pressing [e] causes a return to the run/set up screen.
- Pressing [ENTER] by itself will skip over to the next screen without changing the date format.

Note: The date format is stored with the message.

5. Margin

M e s s a g e M a r g i n	0 2 . 0 0
U s e U p / D n A r r o w s	

- Minimum margin is .80" (20.32 mm). Maximum margin is 40.00" (1016mm). Default is 2.0" (50.8mm).
- Up arrow [↑] and Down arrow [↓] allow increasing or decreasing the margin by 0.1" (2.5mm) increments.
- [Shift] + [↑] and [Shift] + [↓] allow increasing or decreasing the margin by 1.0" (25.4mm)
- Pressing [ENTER] allows movement to next screen.
- Pressing [e] causes a return to the run/set up screen.

NOTE: The message margins are approximate values only. Message margins and print lengths may fluctuate based on conveyor speed changes.

6. Count

C u r r e n t C o u n t	1 2 3 4
N e w C o u n t	

NOTE: When setting the count, the number you enter will be for the next item printed. If you are using the count field as part of your message, if you enter or reset the count to 0 (zero) then that is what will be printed. While zero is a valid mathematical number, it has no real use in counting boxes. So that you don't end up with a 'box #0', when the system reaches the upper limit of all 9's it will roll over to 1.

- Entering one to four digits represents the consecutive count function. *When not in RUN mode, the number of digits entered controls the number of digits printed and displayed, with a minimum of 2 digits and a maximum of 4 digits.*
- Pressing [d] will delete the last digit.
- Pressing [ENTER] will allow movement to the next screen.

7. Width

M e s s a g e W i d t h	1 0 0 %
U s e U p / D n A r r o w s	

- Use up [↑] and down [↓] arrows to scroll through the choices, min – 50%, max – 200%.
- [Shift] + [↑] causes the width to assume the maximum value.
- [Shift] + [↓] causes the width to assume the minimum value.
- Pressing [ENTER] will allow movement to the next screen.

8. Dot Size

D o t S i z e	4
U s e U p / D n A r r o w s	

- Use up arrow [↑] and down arrow [↓] to scroll through the choices, min 1 to a max of 9.
- [Shift] + [↑] causes the dot size to assume maximum value.
- [Shift] + [↓] causes the dot size to assume minimum value.
- Pressing [ENTER] will continue to the ink pressure screen.

I n k P r e s s u r e	3
U s e U p / D n A r r o w s	

- Use the up arrow [↑] key to select high pressure (7psi), or the down arrow [↓] key to select low pressure (3psi).
- Pressing [ENTER] will allow movement to the next screen.

9. Special Field

S p e c i a l F i e l d	0
N e w S p e c i a l	0

A numeric field that can be entered into a message by pressing the [shift] + [**Multi-Function**] key.

MESSAGE ENTRY

(R) R u n / (S) S e t u p
S e l e c t (R / S) ?

Press [R] Key. (Key with the white letter R)

1. Start print?

F I R S T L I N E O F M S G
S t a r t P r i n t (Y / N) ?

- a. Pressing [Y] causes the message displayed to be printed. Green LED under the [On] Key illuminates.
- b. Pressing [N] causes movement to the next screen.

2. Retrieve or enter new?

(N) N e w M e s s a g e o r
M e s s a g e # 0 (# # / N)

- a. Pressing [N] causes movement to the next screen for entering a new message.

3. Enter message.

_ E n t e r M e s s a g e

(See examples next page.)

- a. Use keyboard to type in new message. (These 10 characters can be entered into a message by holding down the shift key and pressing the letters A to J).

\$ (Shift-A)	* (Shift-B)	+ (Shift-C)	/ (Shift-D)	(Shift-E)
: (Shift-F)	< (Shift-G)	> (Shift-H)	[(Shift-I)] (Shift-J)

- b. Pressing the time, date or count function keys will insert them in the message at the current cursor location and font size. Use the [shift] + [**Multi-Function**] key to enter the special field into the message.
- c. Pressing [d] deletes the last character or data field entered.
- d. Pressing the [shift] + [↑] keys shows characters 1 to 20 (beginning) of the message.
- e. Pressing the [shift] + [↓] keys shows characters 41 to 50 (end) of the message.
- f. Pressing [ENTER] causes movement to the save message screen.

4. Save message?

F I R S T L I N E O F M S G
S a v e M e s s a g e (Y / N) ?

- a. Pressing [Y] causes movement to the next screen.
- b. Pressing [N] causes movement to the "Start Print?" screen.

NOTE: The margin, width, dot size and ink pressure settings are saved with the message. They can be changed by using the function keys before pressing [ENTER] to save the message.

5. Enter message #.

E n t e r M s g # 0 0 0
(0 1 t o 2 0 0) + E N T E R

- a. A one, two or three digit (up to 200) entry followed by pressing [ENTER] causes the message to be stored in that memory location.
- b. Pressing [d] deletes the last digit.
- c. At least one digit must be entered.

Calculating the approximate length of the message.

FORMULA: ((# of Characters. * Constant A) – Constant B) * Width = Approximate Length

Nozzleplate Size	CONSTANT A	CONSTANT B
3/8"	.4319	.1234
1/2"	.553	.158
3/4"	.8183	.2338
1.0"	1.0794	.3084

NOTE: Message length calculations are approximate due to the fact that conveyor speeds vary. Once the leading edge of the box passes both photo sensors in the front of the MATRIX I, the speed is calculated and locked in. If the actual conveyor speed then varies, the message length will be affected.

MESSAGE RETRIEVAL FROM MEMORY

(R) R u n / (S) S e t u p S e l e c t (R / S) ?
--

Press the [R] Key.

1. Start print?

F I R S T L I N E O F M S G S t a r t P r i n t (Y / N) ?
--

- a. Pressing [N] causes movement to the next screen.

2. Retrieve or enter new?

(N) N e w M e s s a g e o r M e s s a g e # 0 (# # / N)
--

- a. A one, two or three digit entry followed by pressing [ENTER] causes the message to be retrieved from the memory and causes movement to the "Start print?" screen.

NOTE: With room to store 200 messages, it is suggested that a list of messages along with the corresponding memory number be kept for reference when retrieving messages from the memory. (Photocopies of APPENDIX B can be used for this purpose).

ROUTINE MAINTENANCE

Every morning before startup:

1. Pat nozzle plate with a paper towel dampened with Kiwi Nozzleplate Cleaner. This procedure should also be followed upon shutdown of the MATRIX I System.
2. Flush Print head.
3. Clean the Opto Sensor assembly in front of print head with paper towel dampened with Kiwi Nozzleplate Cleaner.
4. Check all ink fittings for possible ink leaks.
5. Change strainer (F063164) every 180 days. (Contact factory for assistance.)

If the Matrix I system will not be used for more than 2 weeks, it is recommended that Nozzleplate cleaner be used to backflush the system to prevent the ink from drying in the valves. This procedure is done with steps 2 through 4 below, repeated for each valve. (NOTE: It is strongly recommended that a spare male ink fitting, (F060267) is attached to the female ink port in the rear of the Matrix I, to prevent an overpressure situation from popping hoses internally, which could severely damage the electronics. If a spare male ink fitting is not available, the excess pressure **must** be relieved at the female ink port every 1/2 syringe full of solvent.)

BACKFLUSHING NOZZLES.

1. Locate position of clogged nozzle.
2. Fill backflush syringe (F060549) with Kiwi Nozzleplate Cleaner (D060009) only.
3. Place tip of backflush syringe over clogged nozzle.
4. Force solvent from the syringe into nozzle.
5. Flush printhead.
6. Repeat as necessary.

TROUBLESHOOTING

Your Matrix I system is designed to operate trouble free, in an industrial environment. However, if a problem should occur, please review the following troubleshooting guide. Contact Kiwi during our normal business hours (M-F 8am to 4pm Central time) for assistance.

PROBLEM:	POSSIBLE CAUSE:	SOLUTION:
Blank screen.	No line voltage to power supply.	Is line cord plugged in completely? Check for tripped circuit breakers.
	No output from power supply module.	Replace power supply. (P/N F063327)
MATRIX I will not print.	No message entered.	Re-enter message.
	Is system in print mode? (Is green print light on)?	Push the 'on' button, and follow the prompts.
	Is MATRIX I more than 1/2" away from the side of the box?	Move MATRIX I closer to the side of the box.
	The Opto assembly is partially above the box.	Lower the Matrix I until the top of the Print head is even or a bit below the top edge of the box
	Are photoeyes dirty or damaged?	Clean or replace the Opto Sensor Assembly (P/N FC63249).
	Conveyor speed out of range.	Minimum speed is 20 ft/min and maximum speed is 200 ft/min.
	Out of ink.	Replace ink box. Re-prime pump and flush system to remove air if needed.
MATRIX I does not print, but the count increases.	Is the Margin set longer than the carton length?	Set the message margin to an appropriate length.
	Out of ink.	Replace ink box. Re-prime pump and flush system to remove air if needed.
Ink pump module does not pump ink.	Pump overheated.	Unplug Matrix I and allow pump to cool.
	Ink level in box below the level of the pump connector.	Replace with new box of ink, then re-prime pump.
	Pump needs to be primed.	Place MATRIX I in the printing mode. Disconnect the ink line only from the back of the MATRIX I controller. Press the tip of the ink line into a paper towel until ink appears.
	Faulty electrical connection to pump.	Unplug pump, check contacts for corrosion, clean if needed, and re-connect pump.
	Bad pump.	Replace (P/N FC63233)
Dot missing.	Clogged nozzle.	Flush system, and backflush nozzles as required.
	Worn ink valve.	Replace valve. (P/N FC63262)
Poor print quality.	Clogged nozzle.	Flush and backflush as required.
	Air in system.	Flush system.
	MATRIX I controller too far from box.	Move the MATRIX I closer to the side of the box.
	Worn ink valve.	Replace valve. (P/N FC63262)

Case Assembly

Item	Description	Part No.	Qty
1	Screw, Phillips pan head 4-40 x 1/4	F063060	4
2	Assembly, Power Cable	FC63238	1
3	Assembly, Pump Cable	F063239	1
4	Coupling, Panel mounted Ink	F063028	1
5	Standoff, 3/16 x 1/4, 4-40 Male/Female	F095899	4
6	Weldment, Case Panel and Bracket	FC63343	1
7	Nut, 4-40 Keps	F060455	4

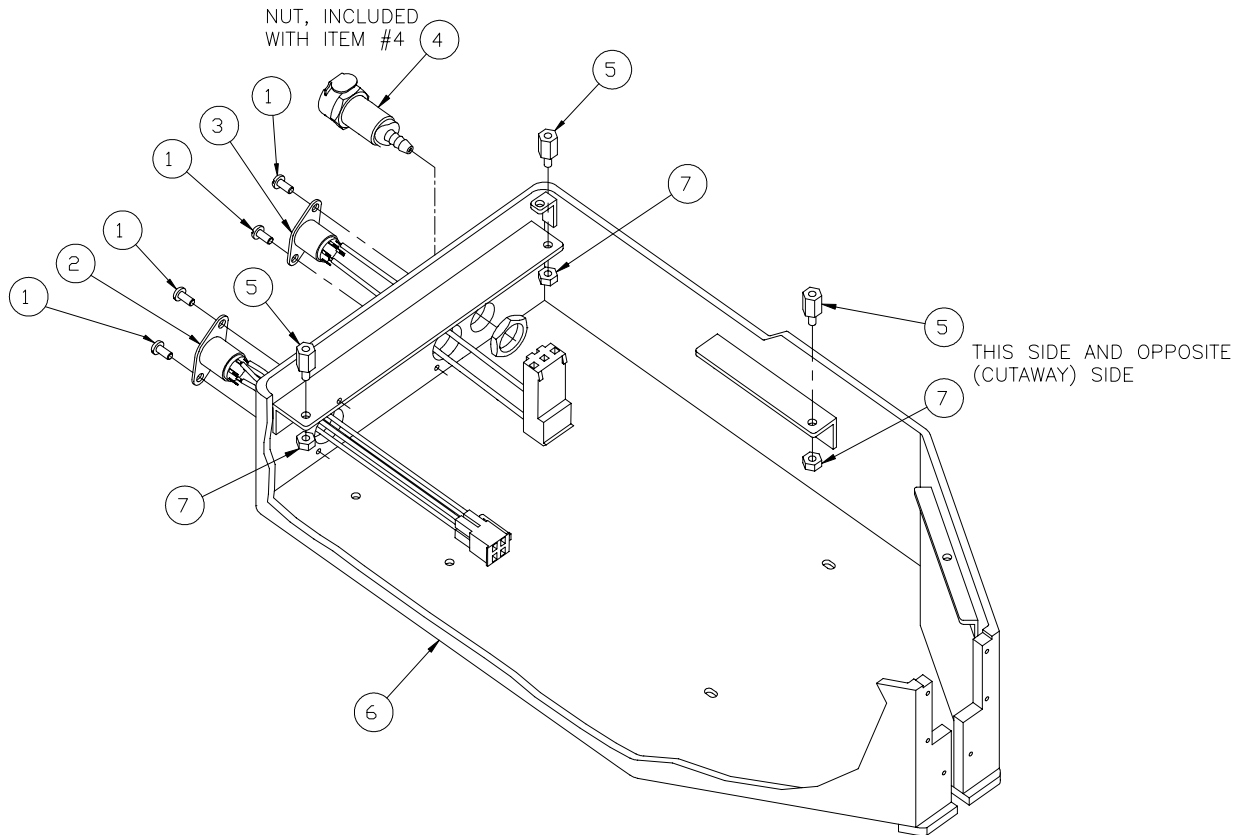

PARTS LIST see Figure on next page

ITEM	DESCRIPTION	PART NO.	QTY
1	Assembly, Case	FC63352	1
2	Screw, 2-56 x 1/4	F094428	6*
3	Assembly, Opto Sensor Plate	FC63249	1
4	Assembly, Ink Manifold	FC63351	1
5	Tube, Tygon, 8" long	FC63259	1
6	2-56 x 1 1/4 screws, phil pan head	F093374	3
8	Tube, Tygon 3 1/4" long	FC63258	1
9	Mtg Bracket, valves	F063339	1
10	Assembly, Main PC board (Keyboard)	FC63216	1
11	Screw, 4-40 x 1/4" phil pan head S.S.	F063060	10
12	Cover, Silk-screened	FC63324	1
13	Tubing, 10" long (Valve to Manifold, not shown)	FC63336	7
14	Keypad	F063008	1
15	Assembly, Strainer	FC63164	1
16	Assembly, Opto cable	FC63237	1
17	Spacer, .125 OD x .188 long	F060804	4
18	Assembly, Ink valve	FC63262	7
19	Valve circuit board, 7 valve	FC63337	1
20	2-56 x 3/4 screws, phil pan head	F093375	2

* 2 screws used to mount Nozzleplate, not shown here.

OPTIONAL SPARE PARTS KIT **FC63367**

ITEM NAME	PART #	QTY.
Back Flush Syringe	F060549	1
Strainer Filter Assembly	F063164	1
Male Ink Coupling (not pictured)	F060267	1
Assembly, Opto Sensor Plate	FC63249	1
Assembly, Ink Valve, with output tube	FC63262	1

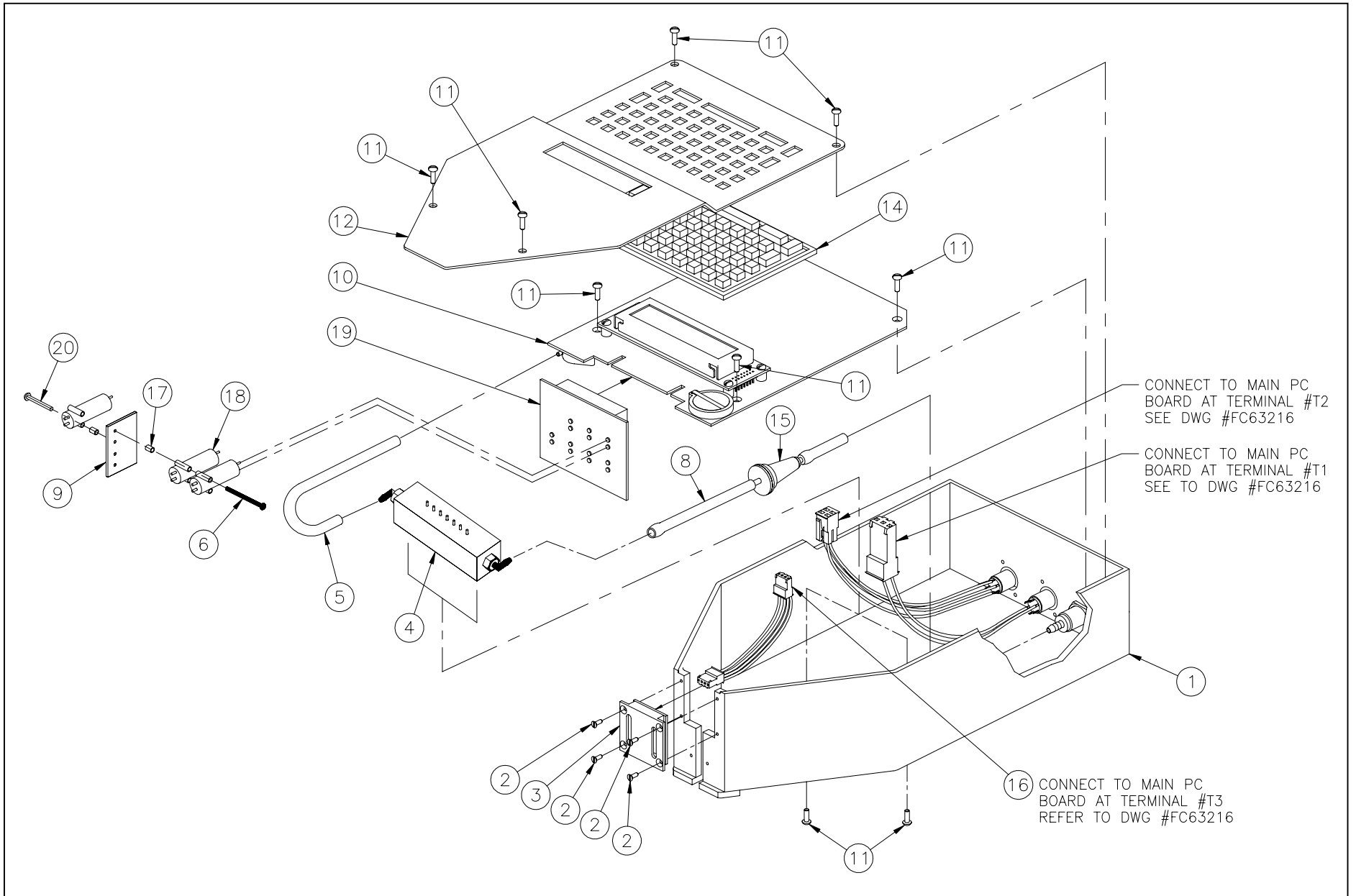

Main Board Assembly

Item	Description	Part No.	Qty
1	Battery	F063107	1
2	Assembly, LCD Display	FC63253	1
3	PC Board, Main	FC63255	1
4	Screw, 4-40 x 1/2 Nylon, Phillips pan head	F095717	1
5	Standoff, 3/16 x 1/4, 4-40 Male/Female	F095899	4
6	Nut, 4-40 Nylon	F095718	1
7	Cpu Module	FC63256	1
8	Screw, 4-40 x 1/4, Phillips pan head	F063060	4
9	Nut, 4-40 Keps	F060455	4

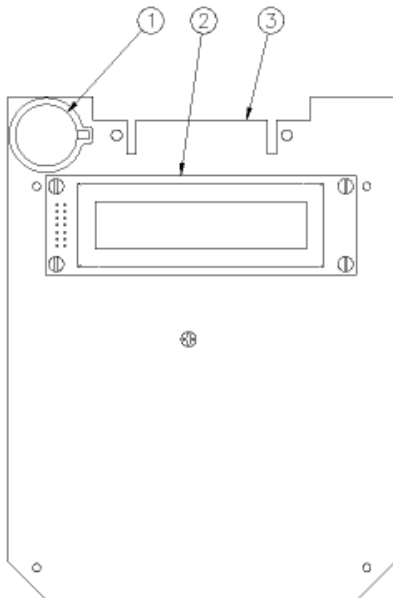

FRONT VIEW

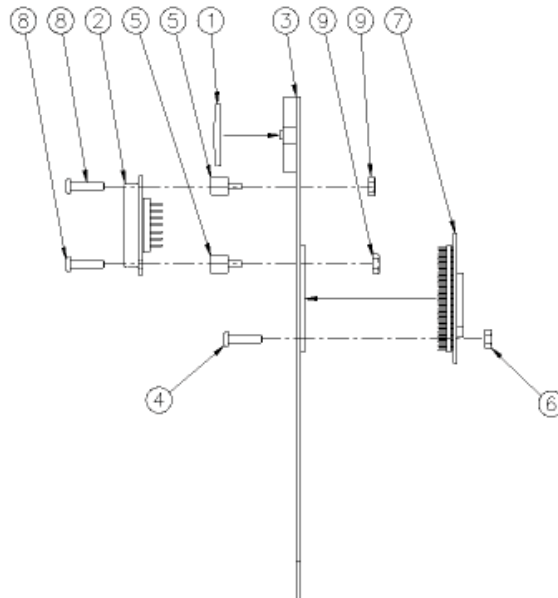

SIDE VIEW

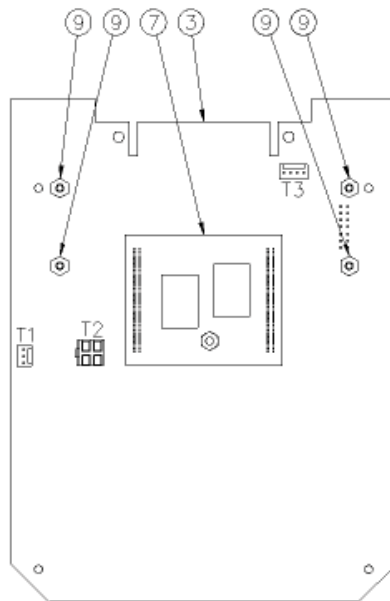

BACK VIEW

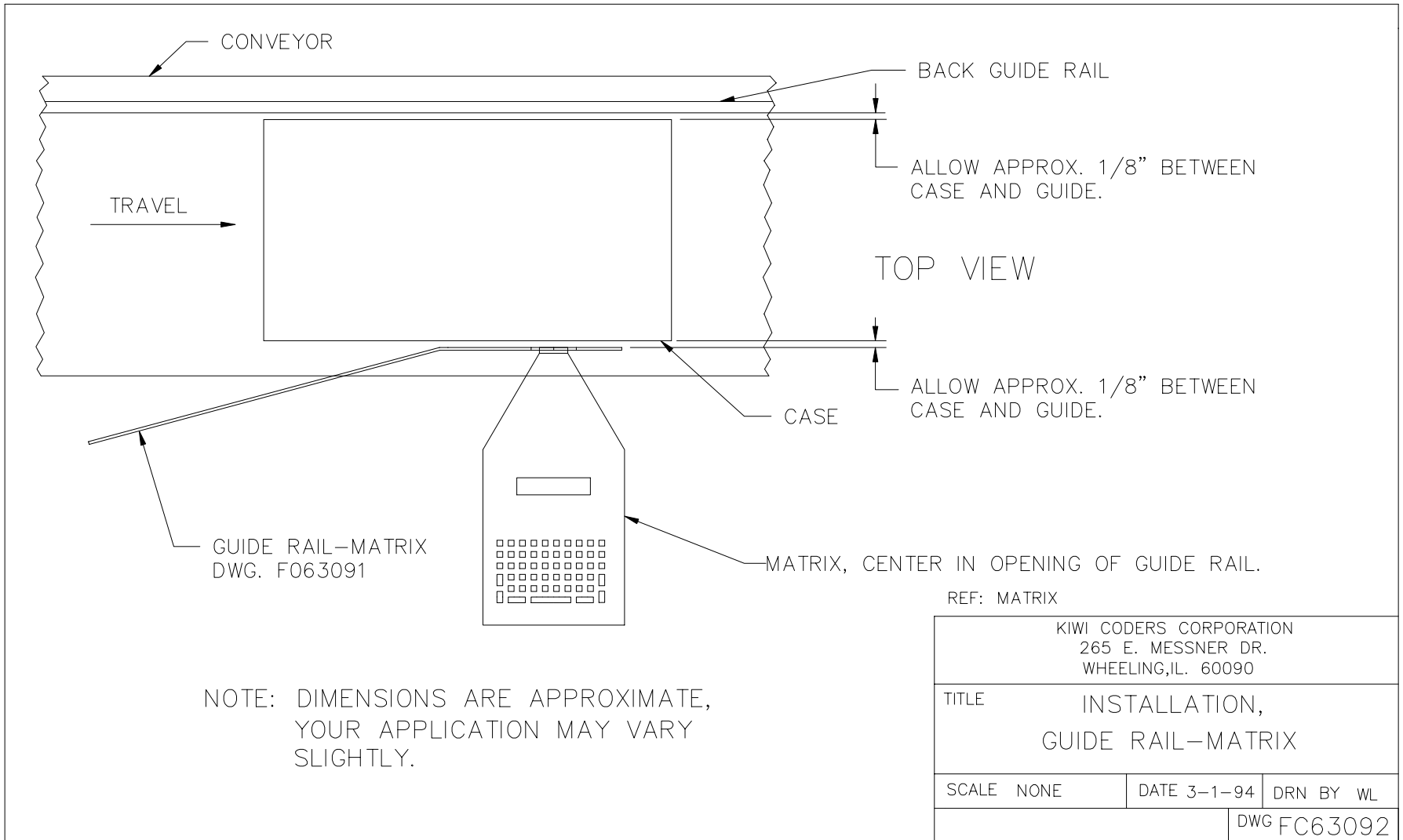

REVISIONS			
SYM	DESCRIPTION	DATE	DRAWN BY

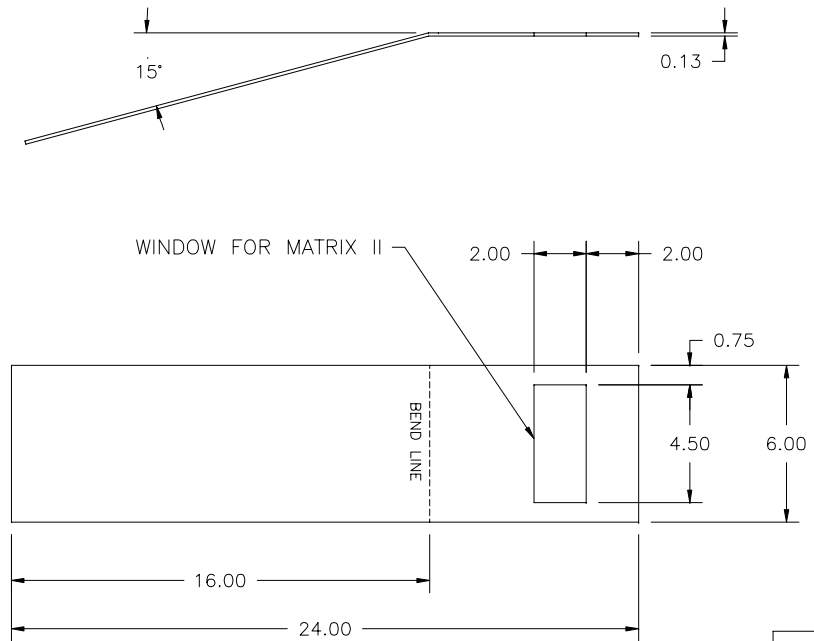

NEXT ASSEMBLY: FC63092 (INSTALLATION DRAWING)
 MATERIAL: C1018 CFS
 REQUIRED: 1 PER ASSEMBLY

CUSTOMER'S NAME:
 REF. MODEL: MATRIX II
 SERIAL NUMBER:

		KIWI CODERS CORPORATION 265 E. MESSNER DR. WHEELING, IL. 60090	
		TITLE GUIDE RAIL FOR THE MATRIX II	
SCALE	NTS	DATE	06/17/02
DRN	BY	DRB	
TOLERANCES UNLESS OTHERWISE SPECIFIED:		DWG FC63276	REV
dec	.00 + .015		
dec	.000 + .005		
ang	± 1/2 deg		

APPENDIX A

CAUTION:

DO NOT remove the screw at the rear of the pump's ink connector.

Instructions for changing an empty box of ink.

1. Disconnect the pump lines from the back of the Matrix I. (Use a paper towel to catch any ink drips.)
2. Pull pump and old box of ink out of the wire basket. Place on a level surface with the pump on top.
3. Pull the metal retaining clip back to unlock the assembly.
4. Holding the Bag-in-box connector with one hand and the pump's ink connector in the other hand, pull up and give a slight twist to separate them. **THERE WILL BE A SMALL AMOUNT OF INK REMAINING IN THE END OF THE PUMP.** Place pump aside while you open a new box of ink.
5. Place a new box of ink with 'perforated punch-out' on top.
6. Pull back the perforated flap but do not remove it.
7. Pull Bag-in-box connector through the hole in the box.
8. Slide it into the notch using the groove closest to the ink bag.
9. Tuck flap of box into the same groove to lock the connector to the side of the box.
10. Remove blue (or orange) protective cap from the bag-in-box connector.
11. Center the pump's ink connector over the Bag-in-box connector. Gently push them together with a slight twisting motion while holding the Bag-in-box connector to prevent it from pushing back into the box.
12. Slide the metal retaining clip into the groove on the pump's ink connector until you feel it snap onto the Bag-in-box connector. This will prevent separation and ink spills.
13. At this point you will need to follow the instructions for priming the pump to remove the air before connecting it back to the Matrix.

Instructions for attaching a new ink pump to a box of ink.

1. Place box of ink with 'perforated punch-out' on top.
2. Pull back the perforated flap but do not remove it.
3. Pull Bag-in-box connector through the hole in the box.
4. Slide it into the notch using the groove closest to the ink bag.
5. Tuck flap of box into the same groove to lock the connector to the side of the box.
6. Remove blue (or orange) protective cap from the bag-in-box connector.
7. On the pump, remove the black protective cap.
8. Center the pump's ink connector over the Bag-in-box connector. Gently push them together with a slight twisting motion while holding the Bag-in-box connector to prevent it from pushing back into the box.
9. Slide the metal retaining clip into the groove on the pump's ink connector until you feel it snap onto the Bag-in-box connector. This will prevent separation and ink spills.
10. Follow instructions for priming the ink pump, found elsewhere in this manual.

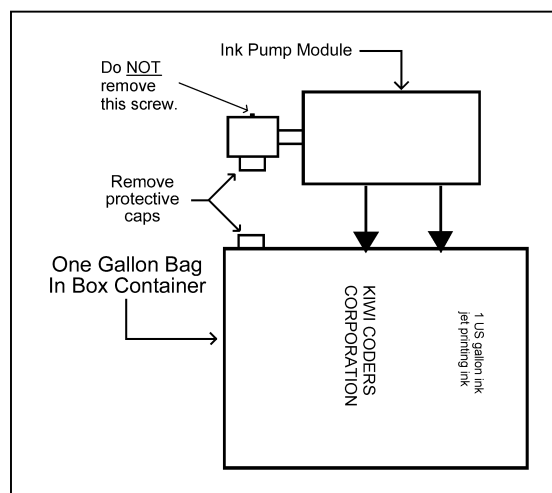

APPENDIX C: Changing a valve.

You will need the following tools:

Small Phillips screwdriver,
Male ink fitting (F060267),
5/32" nut driver,
Small flat bladed screwdriver,
Small pair of needle-nose pliers.

1. Unplug the pump from the rear of the Matrix I housing.
2. Bleed the pressure from the system by inserting a spare male ink fitting *momentarily* into the ink port in the rear panel of the MATRIX I housing. Catch any ink in a paper towel.
3. Remove the Matrix I cover using the small Phillips screwdriver.
4. Remove Opto assembly using the small Phillips screwdriver.
5. Remove nozzleplate assembly using the small Phillips screwdriver.
6. Pull manifold assembly forward slightly to disconnect it from the main board.
7. Remove manifold and nozzleplate assembly from Matrix I housing.
8. Locate the valve to be replaced in the following figure:

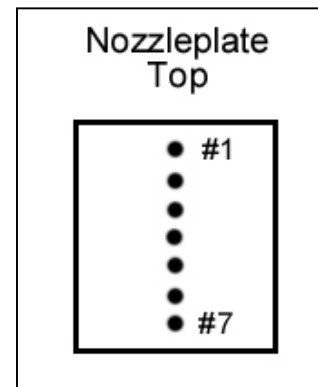
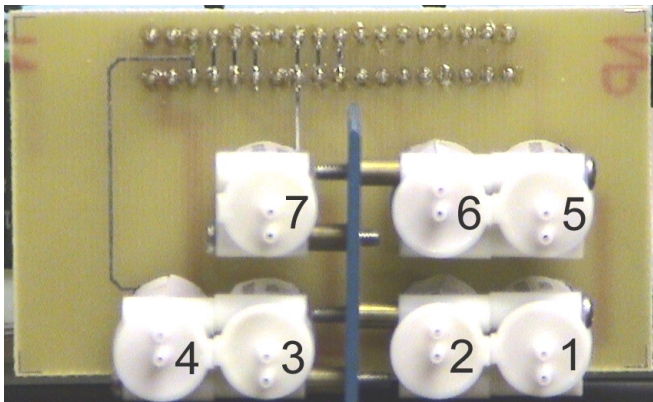

Note: Tubing not shown for clarity

Each pair of valves is held in place by a #2-56 screw. Remove the screw from the pair that contains the valve you will be replacing being careful not to lose the brass spacer. Note the orientation of the valve. Even numbered valves have the supply tube high, and odd numbered valves have the supply tube low (see picture above.) Grasp the tubing of the valve, and gently pull to disconnect the valve's electrical connections. Disconnect the valves input tube (longer, larger diameter tube) by pushing it in slightly to loosen the friction fit and then pulling it off. Using the tip of a small screwdriver, pry the tubing off of the stainless tube at the back of the nozzleplate. *It is recommended that only one valve's input tubing be removed at a time to prevent ink loss and the inclusion of air into the manifold.* Connect the new valve in the reverse order, being careful not to crimp, or allow any dirt into, the end of the tubing. A pair of small needle-nose pliers will help inserting the tubing over the ends of the stainless steel tubes in the nozzleplate. Also, it might become necessary to trim 1/16" to 1/8" off the end of the supply tubing to insure a snug fit to the new valve

NOTES:

NOTES: