

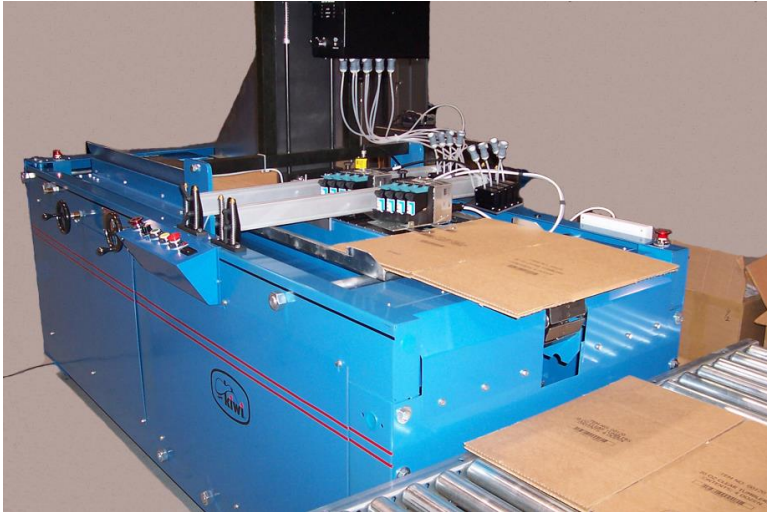

Integrated Hi-Resolution Corrugated Case Printer

The perfect off-line solution for transporting flat corrugated cases and die cut sheets. Significantly reduces inventory when used with ANY **INK JET** system.



Model 2480 shown with roller conveyor catcher.

SPECIFICATIONS:

- Variable speed DC motor drive
- Feed rate: up to 50/minute (rate varies by application)
- Quick adjust magazine feed
- Wide lug plate chain provides positive feed
- Power requirements: 220 Volt, 50/60 Hz, single phase
- Motor: 1 Hp totally enclosed, fan cooled, variable speed with dial control.
- Electrical controls: NEMA Type 1
- Discharge height: 37" (940mm)

OPTIONAL ITEMS

- Top mounting system (shown)
- 5 foot roller conveyor catcher (shown)
- Model SC automatic stacker conveyor (not shown)
- Predetermining or totalizing counter

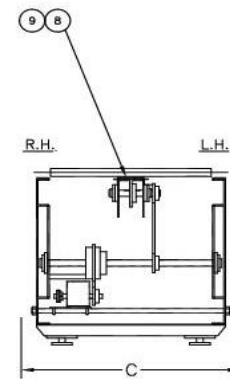
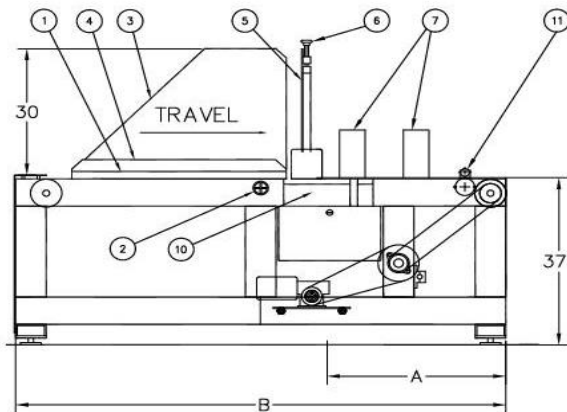

BILL OF MATERIAL:

- | | |
|-------------------------------------|---|
| ① SELF-CENTERING SIDE GUIDES. | ⑧ PLATE CHAIN, 4.5 IN. WIDE. (THE MODEL 4880 HAS TWO 4.5 IN. WIDE PLATE CHAINS ON 8.5 IN. CENTERS, INSTEAD OF ONE AS SHOWN ABOVE). |
| ② HANDWHEEL FOR GUIDES. | ⑨ LUGS FOR PLATE CHAIN ON 48 IN. CHAIN CENTERS. (OPTIONAL CHAIN CENTERS - 24 IN. & 72 IN.). |
| ③ MAGAZINE GUIDE PLATE, LEFT SIDE. | ⑩ ELECTRICAL CONTROL PANEL. |
| ④ MAGAZINE GUIDE PLATE, RIGHT SIDE. | ⑪ OPTIONAL, OUTPUT SPEED-UP ROLLER. THIS IS A REQUIRED OPTION FOR MODELS 2480, 3480, AND 4880 WITH AN OPTIONAL SC STACKER CONVEYOR. |
| ⑤ GATE ASSEMBLY. | |
| ⑥ HANDWHEEL FOR GATE ASSEMBLY. | |
| ⑦ MOUNTING JET PRINTERS. | |

CORR. CASE TRANSPORT (DIMENSIONS ARE SHOW IN INCHES)				
MODEL	MAX. CASE WIDTH	A PRINTING AREA DIM.	B OVERALL MACHINE LENGTH	C WIDTH
2480	26"	48"	144"	43"
3480	36"	48"	144"	53"
4880	50"	48"	144"	67"
*2480S	26"	35"	96"	43"
*3480S	36"	35"	96"	53"

PL11101

Kiwi Coders Corporation, 265 E. Messner Dr. Wheeling, IL 60090 USA
 847-541-4511 (phone) 847-541-6332 (fax)
 e-mail: info@kiwicoders.com Website: www.kiwicoders.com